



**400 mg bupivacaine and 12 mg meloxicam**  
Each mL contains 29.25 mg bupivacaine and 0.88 mg meloxicam

### Intended Use

ZYNRELEF is indicated in adults to produce postsurgical analgesia for up to 72 hours after soft tissue, foot and ankle, and other orthopedic procedures in which direct exposure to articular cartilage is avoided.

### Limitations of Use

Safety and efficacy have not been established in highly vascular surgeries, such as intrathoracic, large 4 or more level spinal, and head and neck procedures.

## Instructions For Use

### Dose Information

A single-dose application of a viscous solution administered directly via a needle-free syringe to coat the affected tissue within the surgical site prior to suturing. Two syringes are provided to aid in application.

### Preparing the Product

Only **withdraw 7 mL** of ZYNRELEF into each syringe. This product does not require mixing. During preparation, do not mix with water, saline or other local anesthetics. Preparation is typically done in the Operating Room. Follow your facility's standard operating procedures regarding aseptic and sterile preparation and disposal of unused contents in the vial.

### Storing the Product

ZYNRELEF kit should be stored at 20°C to 25°C (68°F to 77°F) with excursions permitted between 15°C to 30°C (59°F to 86°F) [See USP Controlled Room Temperature], protected from light and moisture.

### For Operating Room Preparation

It is recommended that a 2-person team prepare this product: one sterile person and one non-sterile person. If product is prepared in advance of surgery, syringe tip caps **4** may be used to cap the syringe until ready for application. Before administration, remove the syringe tip cap and attach the Luer lock applicator **3**.

### The ZYNRELEF Kit Contents

Use only the components listed below supplied for use with ZYNRELEF.

- 1 Vented Vial Spike** (Part #011-CS-75) (sterile)
- 2 12 mL Luer Lock Syringe** (Part #4100-X00V0) (sterile) (2x)
- 3 Luer Lock Applicator** (Part #709689) (sterile) (2x)
- 4 Tip Caps** (Part #305819) (sterile) (2x) (preparation in advance)
- 5 14 mL ZYNRELEF Vial** (contents sterile, exterior not sterile)

Turn over for Administration Information

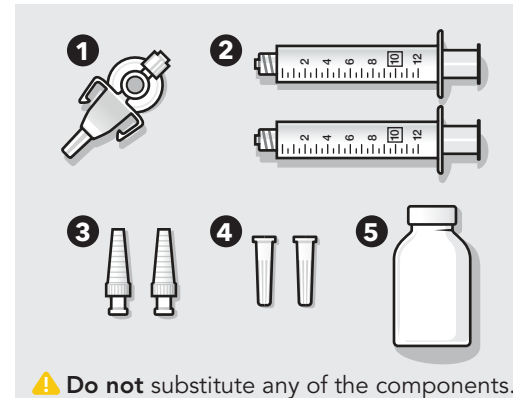

## Preparation

### 1 Prepare Components

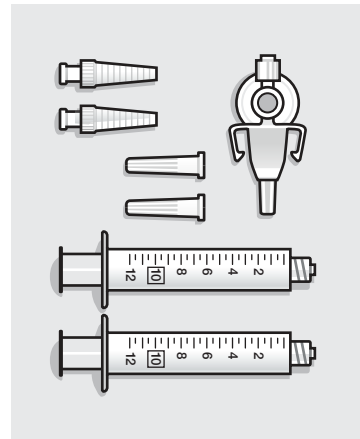

#### STERILE

Open all components onto sterile field.

*Note: Prepare all syringe(s) provided in kit.*

**⚠ Do not substitute any of the components.**

**⚠ Only withdraw 7 mL of ZYNRELEF into each syringe.**

*Note: Vial contains overfill to account for amount that remains in the vial, vented vial spike, Luer lock applicator, and syringe(s) during drug withdrawal and administration.*

### 2 Prepare Vial



#### NON-STERILE

**A)** Flip cap off of vial and place onto stable non-sterile surface.

**B)** Cleanse septum with alcohol wipe.

**C)** Hold the vial in place for the sterile person to safely insert the vented vial spike.

**⚠ Do not remove the stopper or attempt to pour the vial contents.**

### 3 Remove Protective Sheath

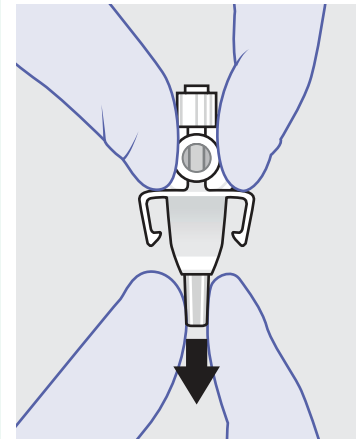

#### STERILE

**A)** Remove blue protective sheath from vented vial spike.

**B)** Remove luer cap.

### 4 Attach Vented Vial Spike

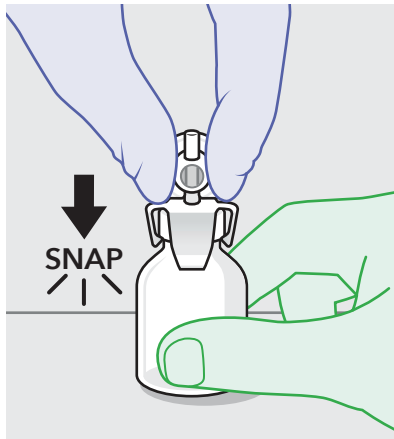

#### STERILE

Push the spike through the septum of the vial until it "snaps" into place.

**⚠ Hold the vented vial spike by the adapter neck to maintain sterility of the vented vial spike and sterile person.**

#### NON-STERILE

Hold the vial in place while sterile person attaches spike.

*Note: Place the vial on a firm, flat surface and hold in place while the sterile person attaches the spike.*

### 5 Prepare Syringe

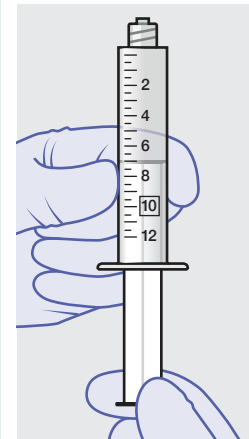

#### STERILE

Fill the syringe with 7 mL of air before attaching to the vented vial spike.

**⚠ Air from syringe will be pushed into the vial at Step 7 after the vial has been inverted and product has filled the neck of the vial.**

### 6 Prepare for Withdrawal

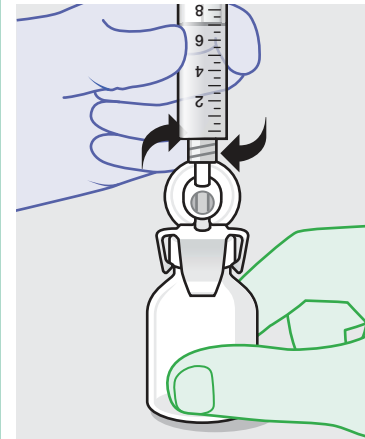

#### STERILE

Attach the air-filled syringe to the vented vial spike.

*Note: Avoid pushing or pumping the plunger rod up and down at any point in the withdrawal process.*

#### NON-STERILE

Hold the vial in place until the syringe is attached.

### 7 Withdraw Product

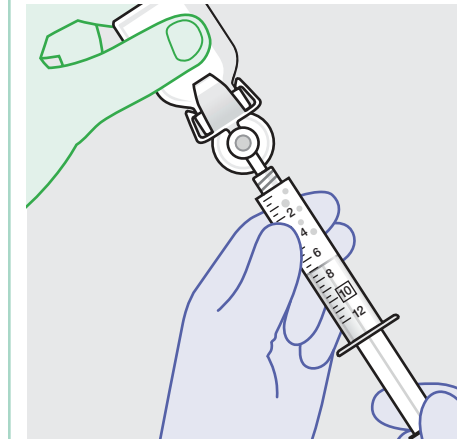

#### STERILE

**A)** Invert the vial using the syringe.

**B)** Allow product to fill the neck of the vial.

**C)** Push air into vial and wait for the air bubble to rise.

**D)** Withdraw 7 mL of product. It is normal for there to be small air bubbles in the syringe.

*Note: Product is very thick. It may take a few minutes to withdraw.*

#### NON-STERILE

You may assist the sterile person with inverting the vial if necessary by holding the non-sterile vial.

### 8 Repeat With Second Syringe

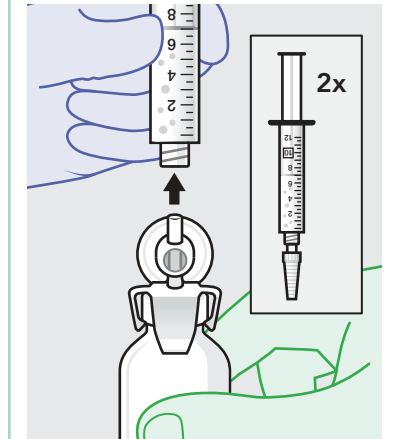

#### STERILE

**A)** Return vial to non-sterile surface.

**B)** Remove syringe from vial and attach Luer lock applicator.

**C)** Place syringe on sterile surface.

**D)** Repeat steps 5–8 with second syringe.

#### NON-STERILE

Hold the vial in place for attachment of second syringe.

### Frequently Asked Questions

**Can I attempt to do the entire preparation process on my own?** It is recommended that this be done as a 2-person team to maintain sterility.

**Is there any way to speed up the withdrawal time?** The withdrawal time is faster when the vial is at the upper end of the recommended storage conditions (25°C or 77°F). Do not dilute this product in any way.

**What if I touch the aluminum collar when attaching the vented vial spike adapter?** Replace your sterile gloves and continue with next steps.

**Do I have to wait until the vial is inverted to push in air?** Proper insertion of air after inverting the vial improves withdrawal time.

**Do I need to dilute this product to expand the volume?** No. The product should not be diluted.

**Can I pour this product in a sterile cup?** No, you will be unable to pull an effective dose from the sterile cup due to the thick nature of the product.

**What should I do if I drop a syringe or any of the other components?** Use replacement kit components that are individually supplied separate from the kit.



400 mg bupivacaine and 12 mg meloxicam  
Each mL contains 29.25 mg bupivacaine and 0.88 mg meloxicam

## Administration Information

Please familiarize yourself with this information before you use this product for the first time.

ZYNRELEF should only be administered with the syringe and Luer lock applicator provided in the ZYNRELEF kit.

### Administration

1. ADMINISTER ZYNRELEF VIA INSTILLATION ONLY.
2. ZYNRELEF should not be administered via the following routes:
  - Epidural
  - Intrathecal
  - Intravascular
  - Intra-articular
  - Regional nerve blocks
  - Pre-incisional or pre-procedural locoregional anesthetic techniques
3. ZYNRELEF is applied without a needle into the surgical site following final irrigation and suction and prior to suturing.
  - ⚠ Only apply ZYNRELEF after final irrigation and suction of each layer before closing, if multiple tissue layers are involved.
4. Using the Luer lock applicator attached to the syringe, apply ZYNRELEF to the tissues within the surgical site that could result in pain generation.
5. Use a sufficient amount to coat the tissues. For small spaces, ensure there is not an excess that could be expressed from the site during closure.
6. Only apply ZYNRELEF to the tissue layers below the skin incision and not directly onto the skin.

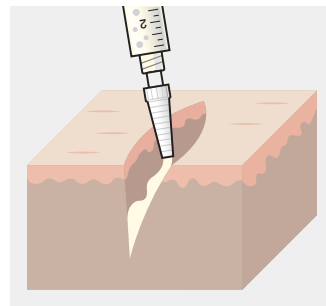

7. ZYNRELEF does not degrade sutures.

⚠ When tying knots with monofilament sutures, contact with ZYNRELEF may cause knots to loosen or untie due to the viscosity of ZYNRELEF. In vitro studies showed an increase in elasticity with monofilament sutures exposed to ZYNRELEF with unknown clinical significance. Minimize administration of ZYNRELEF near the incision line and wipe off excess ZYNRELEF from the skin prior to suturing. Three or more knots ending in a multi-throw knot (e.g. a Surgeon's knot) are recommended with monofilament sutures. Braided or barbed sutures are recommended, especially for closure of deeper layers.

### Important Information

- A. The amount of ZYNRELEF required depends upon the surgical area of tissue to be treated.
- B. ZYNRELEF spreads easily and covers a large area.
- C. Diluting ZYNRELEF is not needed for efficacy.
  - ⚠ ZYNRELEF cannot be mixed with water, saline, or other local anesthetics as the product will become very viscous and difficult to administer.
- D. When ZYNRELEF comes in contact with moisture in the tissues, it becomes more viscous, allowing it to stay in place.
- E. Avoid additional use of local anesthetics within 96 hours following administration of ZYNRELEF.
  - ⚠ Overall local anesthetic exposure must be considered.